

- 22) A fungus infection affected nearly all trees in the woods so that the coloration of the tree bark was changed to a gray-white color. Which graph shows the most probable results that would occur in the distribution of wing coloration in this moth population after a long period of time?

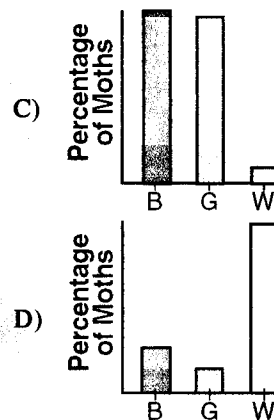
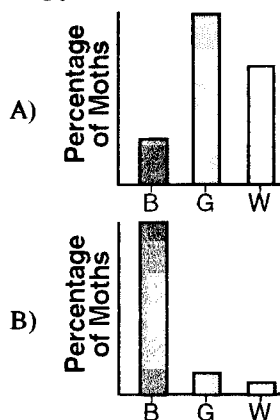

- 23) As a result of the fungus infection, the change in the moth wing color distribution would most probably occur by the
- A) inheritance of an acquired characteristic C) ingestion of pigmentation from fungus spores
 B) production of fungus-induced gene mutations D) natural selection of favorable variations
- 24) The leg structures of many different vertebrates are quite similar in number and location of bones. Most scientists would probably explain this on the basis of
- A) chance occurrence C) needs of the organism
 B) inheritance of acquired traits D) common ancestry
- 25) Which is an example of evidence of evolution based on comparative biochemistry?
- A) The structure of a whale's flipper is similar to that of a human hand.
 B) Human embryos have a tail-like structure at one stage in their development.
 C) Sheep insulin can be substituted for human insulin.
 D) Both birds and bats have wings.
- 26) As a result of sexual reproduction, the rate of evolutionary change in the plant and animal kingdoms has been greatly speeded up because
- A) two parents have fewer offspring than one parent
 B) the offspring show more diversity than in asexual reproduction
 C) environmental changes never affect organisms produced by asexual reproduction
 D) characteristics change less frequently than in asexual reproduction
- 27) **INFORMATION:**
 The Galapagos Islands in the Pacific were probably never connected to South America. However, in the various habitats on the islands, there are about 14 species of finch-like birds that appear to be related to the finches on the South American mainland. Although the Galapagos finches vary in beak structure, there is a close resemblance between these species in plumage, calls, nests, and eggs. These species do not interbreed and do not compete for food.

STATEMENT:

Isolation from the South American mainland and different habitats on the Galapagos Islands are important factors in the production of new species.

What is the relationship between the statement and the information given?

- A) No relevant information is given regarding the statement.
 B) The statement is contradicted by the information given.
 C) The statement is supported by the information given.
 D) The statement is not supported by the information given.

Questions 39 and 40 refer to the following:

The graph below illustrates changes in the percentages of two varieties of a certain species.

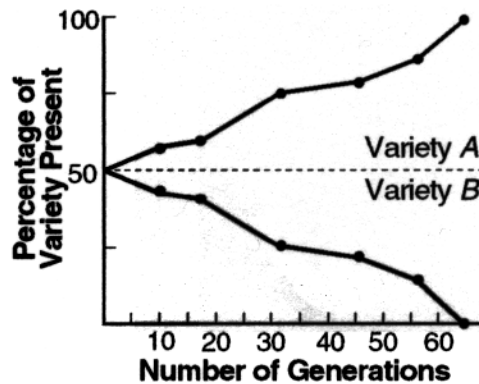

- 39) Which variety will contribute significantly to the future of the species gene pool?
- A) variety *A*, only
 B) both variety *A* and *B*
 C) neither variety *A* nor variety *B*
 D) variety *B*, only
- 40) What is the most probable reason that the percentage of variety *A* is increasing in the population of this species?
- A) Variety *A* is somehow less fit to survive than variety *B*.
 B) There is no genetic difference between variety *A* and variety *B*.
 C) Variety *A* has some adaptive advantage that variety *B* does not.
 D) There is no chance for variety *A* to mate with variety *B*.
- 41) A weakness in Darwin's original theory of evolution was that
- A) natural selection does not occur in domestic animals
 B) competition occurs in animals but not in plants
 C) the genetic basis for variation was not explained
 D) overproduction never occurs in nature
- 42) A change which affects the base sequence in an organism's DNA by the addition, deletion, or substitution of a single base is known as
- A) gene mutation
 B) chromosomal mutation
 C) independent assortment
 D) DNA replication
- 43) Which concept was *not* included by Darwin in his theory of evolution?
- A) genetic basis for variations
 B) struggle for existence
 C) overproduction in a population
 D) survival of the fittest

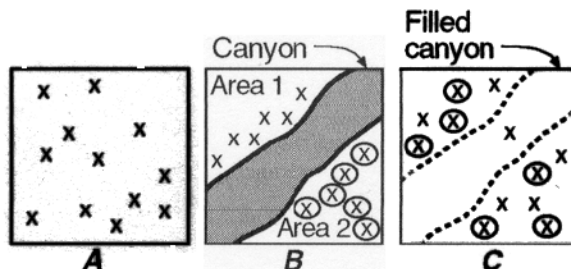

The diagrams represent the changes in a habitat containing a population of nonflying insects, represented by \times , over a period of time. Diagram *A* represents the distribution of these insects before a major canyon was formed. Diagram *B* represents the distribution of insects after a canyon was formed, and diagram *C* represents the insect distribution after the canyon was filled in as a result of a shift in the Earth's surface.

The population of insects in diagram *A* is composed of a large number of organisms. This population's gene pool would most likely remain relatively stable if

- A) mutations were common
 B) an environmental change occurred
 C) migration of species \times occurred
 D) mating were random

45) The scientist most closely associated with the theory of use and disuse is

- A) Lamarck B) Wilkins C) Mendel D) Darwin

Questions 46 and 47 refer to the following:

The information below represents a change in a portion of the base sequence in a DNA molecule.

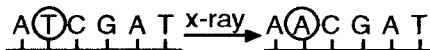

46) One important result of this type of change is that it

- A) involves many chromosomes at once C) prevents a change in the organism's phenotype
B) may be passed on to offspring D) never affects an organisms genotype

47) This change can *best* be interpreted as

- A) nucleic acid replication C) gene replication
B) protein synthesis D) a gene mutation

48) The diagram below represents a DNA molecule.

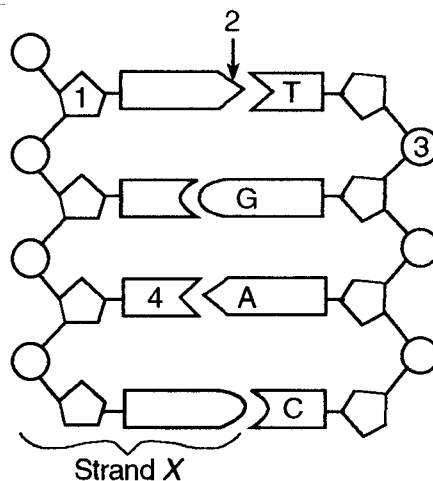

A change in the sequence of T, G, A, and C would result in

- A) polyploidy B) a sex-linked gene C) nondisjunction D) a gene mutation

49) Two squirrel populations are prevented from mating only because they live on opposite sides of the Colorado River. This situation is an example of

- A) geographic isolation C) natural selection
B) reproductive isolation D) adaptive radiation

50) Two organisms can be considered to be of different species if they

- A) cannot mate with each other and produce fertile offspring
B) have genes drawn from the same gene pool
C) live in two different geographical areas
D) mutate at different rates depending on their environment

- 1) A
- 2) A
- 3) C
- 4) A
- 5) B
- 6) D
- 7) B
- 8) C
- 9) B
- 10) B
- 11) B
- 12) D
- 13) C
- 14) C
- 15) B
- 16) C
- 17) B
- 18) B
- 19) D
- 20) A
- 21) A
- 22) A
- 23) D
- 24) D
- 25) C
- 26) B
- 27) C
- 28) B
- 29) D

- 30) C
- 31) D
- 32) A
- 33) B
- 34) A
- 35) B
- 36) C
- 37) C
- 38) D
- 39) A
- 40) C
- 41) C
- 42) A
- 43) A
- 44) D
- 45) A
- 46) B
- 47) D
- 48) D
- 49) A
- 50) A