

Chemistry Review

Section 1 - Chemistry Review

1) In which set do the elements exhibit the most similar chemical properties?

- (a) N, O, and F (c) Li, Na, and K
(b) Hg, Br, and Rn (d) Al, Si, and P

2) As the elements in Group 15 are considered in order of increasing atomic number, which sequence in properties occurs?

- (a) nonmetal → metalloid → metal
(b) metalloid → metal → nonmetal
(c) metal → metalloid → nonmetal
(d) metal → nonmetal → metalloid

3) Which sample contains a total of 9.0×10^{23} atoms?

- (a) 0.50 mole of HCl (c) 1.5 moles of Cu
(b) 0.75 mole of H₂O (d) 1.5 moles of H₂

4) An element with an electronegativity of 0.9 bonds with an element with an electronegativity of 3.1. Which phrase best describes the bond between these elements?

- (a) mostly ionic in character and formed between two nonmetals
(b) mostly ionic in character and formed between a metal and a nonmetal
(c) mostly covalent in character and formed between two nonmetals
(d) mostly covalent in character and formed between a metal and a nonmetal

5) The elements Li and F combine to form an ionic compound. The electron configurations in this compound are the same as the electron configurations of atoms in Group

- (a) 1 (c) 17
(b) 14 (d) 18

6) What is the total number of moles of sulfur atoms in 1 mole of Fe₂(SO₄)₃?

- (a) 1 (c) 3
(b) 15 (d) 17

7) What is the volume occupied by 2.00 moles of Ar(g) at STP?

- (a) 22.4 L (c) 89.6 L
(b) 44.8 L (d) 179 L

8) Electronegativity is a measure of an atom's ability to

- (a) attract the electrons in the bond between the atom and another atom
(b) repel the electrons in the bond between the atom and another atom
(c) attract the protons of another atom
(d) repel the protons of another atom

9) The observed regularities in the properties of elements are periodic functions of their

- (a) atomic numbers (c) oxidation states
(b) mass numbers (d) nonvalence electrons

10) What is the total number of nitrogen atoms in 0.25 mole of NO₂ gas?

- (a) 1.5×10^{23} (c) 3.0×10^{23}
(b) 6.0×10^{23} (d) 1.2×10^{24}

11) The elements calcium and strontium have similar chemical properties because they both have the same

- (a) atomic number
(b) mass number
(c) number of valence electrons
(d) number of completely filled sublevels

12) Which characteristic describes most nonmetals in the solid phase?

- (a) good conductors of electricity
- (b) good conductors of heat
- (c) malleable
- (d) brittle

13) What is the total number of moles of hydrogen atoms contained in 1 mole of $(\text{NH}_4)_2\text{C}_2\text{O}_4$?

- (a) 6
- (b) 2
- (c) 8
- (d) 4

14) Which element in Period 4 is classified as an active nonmetal?

- (a) Ga
- (b) Ge
- (c) Br
- (d) Kr

15) Which electron-dot symbol represents an atom of chlorine in the ground state?

- (a) $\text{Cl}:$
- (b) $\cdot\ddot{\text{Cl}}\cdot$
- (c) $:\ddot{\text{Cl}}\cdot$
- (d) $:\ddot{\text{Cl}}:$

16) An element with a partially filled *d* sublevel in the ground state is classified as

- (a) halogen
- (b) a transition metal
- (c) an alkali metal
- (d) an alkaline earth metal

17) Which electron dot symbol represents the atom in Period 4 with the highest first ionization energy?

- (a) $\ddot{\text{X}}$
- (b) $\ddot{\text{X}}\cdot$
- (c) $\cdot\ddot{\text{X}}\cdot$
- (d) $:\ddot{\text{X}}:$

18) Which type of bond is formed when an atom of potassium transfers an electron to a bromine atom?

- (a) metallic
- (b) ionic
- (c) nonpolar covalent
- (d) polar covalent

19) Compared to the charge and mass of a proton, an electron has

- (a) the same charge and a smaller mass
- (b) the same charge and the same mass
- (c) an opposite charge and a smaller mass
- (d) an opposite charge and the same mass

20) What is the total number of electrons needed to completely fill all of the orbitals in an atom's second principal energy level?

- (a) 16
- (b) 2
- (c) 8
- (d) 4

21) Within Period 2 of the Periodic Table, as the atomic number increases, the atomic radius generally

- (a) decreases
- (b) increases
- (c) remains the same

22) Given the reaction:

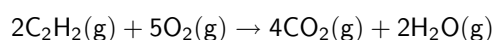

What is the total number of grams of $\text{O}_2(\text{g})$ needed to react completely with 0.50 mole of $\text{C}_2\text{H}_2(\text{g})$?

- (a) 10. g
- (b) 40. g
- (c) 80. g
- (d) 160 g

23) Which equation is correctly balanced?

- (a) $\text{H}_2 + \text{O}_2 \rightarrow \text{H}_2\text{O}$
- (b) $\text{Ca} + \text{Cl}_2 \rightarrow \text{CaCl}$
- (c) $2\text{H}_2 + \text{O}_2 \rightarrow 2\text{H}_2\text{O}$
- (d) $\text{Ca} + \text{Cl}_2 \rightarrow \text{Ca}_2\text{Cl}$

24) What are the characteristics of a neutron?

- (a) It has no charge and no mass.
- (b) It has no charge and a mass of 1 amu.
- (c) It has a charge of +1 and no mass.
- (d) It has a charge of +1 and a mass of 1 amu.

25) What is the total number of neon atoms contained in 20.2 grams of neon gas?

- (a) 1.01×10^{24}
- (b) 2.02×10^{24}
- (c) 3.01×10^{23}
- (d) 6.02×10^{23}

26) Which structural formula represents a nonpolar molecule?

- (a) $\text{H}-\text{Cl}$
- (b) $\begin{array}{c} \text{H}-\text{O} \\ | \\ \text{H} \end{array}$
- (c) $\text{H}-\text{H}$
- (d) $\begin{array}{c} \text{H}-\text{N}-\text{H} \\ | \\ \text{H} \end{array}$

27) One mole of O_2 has approximately the same mass as one mole of

- (a) CH_4
- (b) S
- (c) LiH
- (d) Cl_2

28) Which properties are most common in nonmetals?

- (a) low ionization energy and low electronegativity
- (b) low ionization energy and high electronegativity
- (c) high ionization energy and low electronegativity
- (d) high ionization energy and high electronegativity

29) In which group of elements do most atoms have completely filled *s* and *p* valence sublevels?

- (a) halogens
- (b) noble gases
- (c) alkali metals
- (d) alkaline earth metals

30) Pure silicon is chemically classified as a metalloid because silicon

- (a) is malleable and ductile
- (b) is an excellent conductor of heat and electricity
- (c) exhibits hydrogen bonding
- (d) exhibits metallic and nonmetallic properties

31) Which element has a total of 5 valence electrons present in the fifth energy level?

- (a) Sb
- (b) Bi
- (c) I
- (d) Br

32) Electrostatic attractive forces cause ions of opposite charge to group into a three-dimensional pattern of stacked ions called-

- (a) a crystalline solid.
- (b) a crystal lattice.
- (c) an ionic bond.
- (d) an ionic compound.

33) What happens when $\text{NaCl}(s)$ is dissolved in water?

- (a) Cl^- ions are attracted to the oxygen atoms of water molecules.
- (b) Na^+ ions are attracted to the oxygen atoms of water molecules.
- (c) Cl^- ions are repelled by the hydrogen atoms of water molecules.
- (d) Na^+ ions are repelled by the oxygen atoms of water molecules.

34) In a salt crystal, NaCl , how does the number of positive sodium ions compare with the number of negative chloride ions?

- (a) The number of positive ions is less than the number of negative ions.
- (b) The number of positive ions is more than the number of negative ions.
- (c) The number of positive ions is equal to the number of negative ions.
- (d) It depends on the particular crystal.

35) Which pair of atoms is held together by a covalent bond?

- (a) HCl (c) NaCl
(b) LiCl (d) KCl

36) Two fluorine atoms are held together by a covalent bond. Which statement correctly describes this bond?

- (a) It is polar and forms a polar molecule.
(b) It is polar and forms a nonpolar molecule.
(c) It is nonpolar and forms a polar molecule.
(d) It is nonpolar and forms a nonpolar molecule.

37) Given the unbalanced equation:

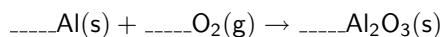

When this equation is correctly balanced using *smallest* whole numbers, what is the coefficient of $\text{O}_2\text{(g)}$?

- (a) 6 (c) 3
(b) 2 (d) 4

38) Experiments performed to reveal the structure of atoms led scientists to conclude that an atom's

- (a) positive charge is evenly distributed throughout its volume
(b) negative charge is mainly concentrated in its nucleus
(c) mass is evenly distributed throughout its volume
(d) volume is mainly unoccupied

39) As the number of neutrons in the nucleus of a given atom of an element increases, the atomic number of that element

- (a) decreases (c) remains the same
(b) increases

40) 24 grams of carbon equals how many moles?

- (a) 1
(b) 2
(c) 3
(d) 4

41) The nucleus of which atom contains 48 neutrons?

- (a) ${}_{16}^{32}\text{S}$ (c) ${}_{37}^{85}\text{Rb}$
(b) ${}_{22}^{48}\text{Ti}$ (d) ${}_{48}^{112}\text{Cd}$

42) How many grams of carbon are in 3 moles of CO_2 ?

- (a) 12
(b) 24
(c) 36
(d) 48

43) The atomic mass unit is defined as exactly $\frac{1}{12}$ the mass of an atom of

- (a) ${}_{6}^{12}\text{C}$ (c) ${}_{12}^{24}\text{Mg}$
(b) ${}_{6}^{14}\text{C}$ (d) ${}_{12}^{26}\text{Mg}$

44) Which sample is composed of particles arranged in a regular geometric pattern?

- (a) $\text{Cl}_2\text{(g)}$ (c) LiCl(s)
(b) $\text{CCl}_4\text{(l)}$ (d) LiCl(aq)

45) Which molecule exhibits covalent bonding?

- (a) LiF
(b) CO_2
(c) KBr
(d) CaC_2

46) The gram atomic mass of oxygen is 16.0 grams per mole. How many atoms of oxygen does this mass represent?

- (a) 16.0 (c) 6.02×10^{23}
(b) 32.0 (d) $2(6.02 \times 10^{23})$

47) Which pair of atoms will share electrons when a bond is formed between them?

- (a) Ba and I (c) K and Cl
(b) Br and Cl (d) Li and I

48) The table below shows some properties of elements A, B, C, and D.

Element	Ionization Energy	Electronegativity	Conductivity of Heat and Electricity
A	low	low	low
B	low	low	high
C	high	high	low
D	high	high	high

Which element is most likely a nonmetal?

- (a) A (c) C
(b) B (d) D

49) What is the total number of valence electrons in an atom of xenon?

- (a) 0 (c) 8
(b) 2 (d) 18

50) Which of these Group 14 elements has the most metallic properties?

- (a) C (c) Si
(b) Ge (d) Sn

51) The bond between hydrogen and oxygen in a water molecule is classified as

- (a) ionic and nonpolar
(b) ionic and polar
(c) covalent and nonpolar
(d) covalent and polar

52) The ability to conduct electricity in the solid state is a characteristic of metallic bonding. This characteristic is best explained by the presence of

- (a) high ionization energies
(b) high electronegativities
(c) mobile electrons
(d) mobile protons

53) Atoms of which element have the *weakest* attraction for electrons?

- (a) Na (c) Si
(b) P (d) S

54) Which compound contains the greatest percentage of chlorine by mass?

- (a) HCl (c) FeCl₂
(b) NaCl (d) ZnCl₂

55) Which orbital notation represents a boron atom in the ground state?

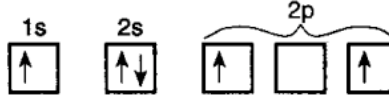
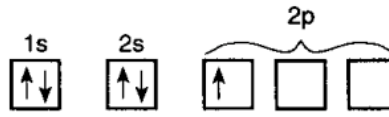
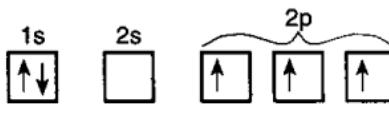
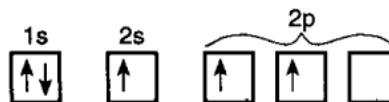
- (a) 
- (b) 
- (c) 
- (d) 

56) Given the balanced equation:

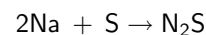

What is the total number of moles of S that reacted when 4.0 moles of Na were completely consumed?

- (a) 1.0 mole (c) 0.5 mole
(b) 2.0 moles (d) 4.0 moles

57) In which two atoms do both nuclides contain the same number of neutrons?

- (a) $^{20}_{10}\text{Ne}$ and $^{40}_{18}\text{Ar}$
(b) $^{65}_{29}\text{Cu}$ and $^{65}_{30}\text{Zn}$
(c) $^{24}_{12}\text{Mg}$ and $^{26}_{12}\text{Mg}$
(d) $^{14}_6\text{C}$ and $^{16}_8\text{O}$

- 58)** An experiment in which alpha particles were used to bombard thin sheets of gold foil led to the conclusion that an atom is composed mostly of
- empty space and has a small, negatively charged nucleus
 - empty space and has a small, positively charged nucleus
 - a large, dense, positively charged nucleus
 - a large, dense, negatively charged nucleus

59) Which substance contains a bond with the greatest ionic character?

- | | |
|---------|---------------------|
| (a) KCl | (c) Cl ₂ |
| (b) HCl | (d) F ₂ |

60) What is the charge and mass of a proton?

- charge of +1 and mass of 1 amu
- charge of +1 and mass of $\frac{1}{1836}$ amu
- charge of -1 and mass of 1 amu
- charge of -1 and mass of $\frac{1}{1836}$ amu

61) When a potassium atom reacts with bromine, the potassium, atom will

- | | |
|--------------------------|--------------------------|
| (a) lose only 1 electron | (c) gain only 1 electron |
| (b) lose 2 electrons | (d) gain 2 electrons |

62) An example of a binary compound is

- | | |
|----------------------|------------------------------------|
| (a) He | (c) H ₂ |
| (b) H ₂ O | (d) H ₂ SO ₄ |

63) What is the total number of atoms contained in a 1.00-mole sample of helium?

- | | |
|----------------|---------------------------------|
| (a) 1.00 atom | (c) 1.20×10^{24} atoms |
| (b) 2.00 atoms | (d) 6.02×10^{23} atoms |

64) What is the most probable location of an electron?

- an orbital
- a nucleus
- a sublevel
- a principal energy level

65) Which structural formula represents a polar molecule?

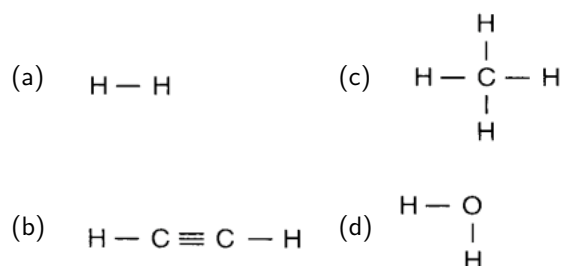

66) The properties of carbon are expected to be most similar to those of

- | | |
|--------------|----------------|
| (a) boron | (c) silicon |
| (b) aluminum | (d) phosphorus |

67) An atom with the electron configuration $1s^2 2s^2 2p^6 3s^2$ would most likely

- decrease in size as it forms a positive ion
- increase in size as it forms a positive ion
- decrease in size as it forms a negative ion
- increase in size as it forms a negative ion

68) At which location in the Periodic Table would the most active metallic element be found?

- in Group 1 at the top
- in Group 1 at the bottom
- in Group 17 at the top
- in Group 17 at the bottom

69) The four single bonds of a carbon atom in CH₄ are directed toward the corners of a

- | | |
|-----------------|-------------------|
| (a) square | (c) rectangle |
| (b) tetrahedron | (d) parallelogram |

70) Given the unbalanced equation:

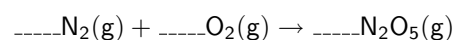

When the equation is balanced using *smallest* whole numbers, the coefficient of N₂(g) will be

- | | |
|-------|-------|
| (a) 1 | (c) 5 |
| (b) 2 | (d) 4 |

71) Which atom will form an ionic bond with a Br atom?

- (a) N (c) O
(b) Li (d) C

72) Experiments with gold foil indicated that atoms

- (a) usually have a uniform distribution of positive charges
(b) usually have a uniform distribution of negative charges
(c) contain a positively charged, dense center
(d) contain a negatively charged, dense center

73) Which atoms are isotopes of the same element?

- (a) ${}_{12}^{24}\text{X}$ and ${}_{12}^{25}\text{X}$ (c) ${}_{15}^{31}\text{X}$ and ${}_{16}^{32}\text{X}$
(b) ${}_{10}^{20}\text{X}$ and ${}_{11}^{20}\text{X}$ (d) ${}_{19}^{31}\text{X}$ and ${}_{19}^{31}\text{X}$

74) At STP, 3×10^{23} molecules of $\text{SO}_2(\text{g})$ occupy the same volume as

- (a) 1 mole of $\text{H}_2(\text{g})$ (c) 0.5 mole of $\text{H}_2(\text{g})$
(b) 6×10^{23} molecules of $\text{H}_2(\text{g})$ (d) 4 grams of $\text{H}_2(\text{g})$

75) Given the equation:

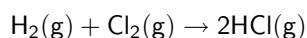

What is the total number of moles of $\text{HCl}(\text{g})$ produced when 3 moles of $\text{H}_2(\text{g})$ is completely consumed?

- (a) 5 moles (c) 3 moles
(b) 2 moles (d) 6 moles

76) How does the size of a barium ion compare to the size of a barium atom?

- (a) The ion is smaller because it has fewer electrons.
(b) The ion is smaller because it has more electrons.
(c) The ion is larger because it has fewer electrons.
(d) The ion is larger because it has more electrons.

77) Given the reaction:

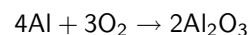

What is the total number of moles of aluminum oxide that can be formed when 54 grams of aluminum reacts completely with oxygen?

- (a) 1.0 mole (c) 3.0 moles
(b) 2.0 moles (d) 4.0 moles

78) Given the electron dot diagram:



The electrons in the bond between hydrogen and fluorine are more strongly attracted to the atom of

- (a) hydrogen, which has the higher electronegativity
(b) fluorine, which has the higher electronegativity
(c) hydrogen, which has the lower electronegativity
(d) fluorine, which has the lower electronegativity

79) If M represents an element in Group 2, the formula of its chloride would be

- (a) MCl (c) M_2Cl
(b) MCl_2 (d) M_2Cl_2

80) Which statement about the mass of an electron is correct?

- (a) The mass of an electron is equal to the mass of a proton.
(b) The mass of an electron is less than the mass of a proton.
(c) The mass of an electron is equal to the mass of a neutron.
(d) The mass of an electron is greater than the mass of a neutron.

81) Which element has a crystalline lattice composed of positive ions through which electrons flow freely?

- (a) bromine (c) carbon
(b) calcium (d) sulfur

82) What is the chemical formula for copper (II) chlorate?

- (a) Cu_2Cl (c) Cu_2ClO_3
(b) CuCl_2 (d) $\text{Cu}(\text{ClO}_3)_2$

83) As the elements of Group I are considered in order from top to bottom, the first ionization energy of each successive element will

- (a) decrease (c) remain the same
(b) increase

84) Given the balanced equation:

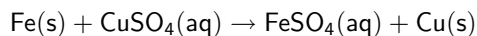

What total mass of iron is necessary to produce 1.00 mole of copper?

- (a) 26.0 g (c) 112 g
(b) 55.8 g (d) 192 g

85) Which compound has the greatest degree of ionic character?

- (a) NaF (c) AlF_3
(b) MgF_2 (d) SiF_4

86) Given the balanced equation:

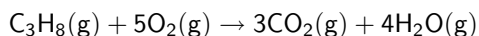

What is the total number of liters of $\text{CO}_2(\text{g})$ produced when 20.0 liters of $\text{O}_2(\text{g})$ are completely consumed?

- (a) 12.0 L (c) 3.00 L
(b) 22.4 L (d) 5.00 L

87) Atoms of metals tend to

- (a) lose electrons and form negative ions
(b) lose electrons and form positive ions
(c) gain electrons and form negative ions
(d) gain electrons and form positive ions

88) Elements in the Periodic Table are arranged according to their

- (a) atomic number (c) relative activity
(b) atomic mass (d) relative size

89) Which electron dot diagram represents a molecule that has a polar covalent bond?

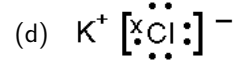
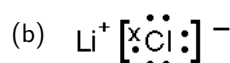
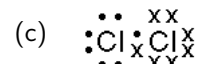
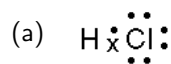

90) Which elements are both classified as metalloids?

- (a) Ge and As (c) B and C
(b) Bi and Po (d) Si and P

91) Which of the following elements has the strongest attraction for electrons?

- (a) boron (c) oxygen
(b) aluminum (d) sulfur

92) Which particles may be gained, lost, or shared by an atom when it forms a chemical bond?

- (a) protons (c) neutrons
(b) electrons (d) nucleons



93) Which atom in the ground state has three half-filled orbitals?

- (a) P (c) Al
(b) Si (d) Li

94) What is the total number of valence electrons in an atom of boron in the ground state?

- (a) 1 (c) 3
(b) 7 (d) 5

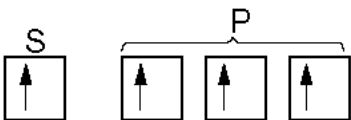
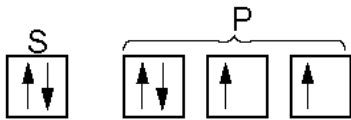
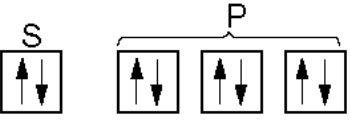
95) Which orbital notation correctly represents a noble gas in the ground state?

- (a) 
- (b) 
- (c) 
- (d) 

96) Which sample contains a total of 6.0×10^{23} atoms?

- (a) 23 g Na (c) 42 g Kr
(b) 24 g C (d) 78 g K

97) Which substance has the greatest molecular mass?

- (a) H_2O_2 (c) CF_4
(b) NO (d) I_2

98) The properties of silicon are characteristic of

- (a) a metal, only
(b) a nonmetal, only
(c) both a metal and a nonmetal
(d) neither a metal nor a nonmetal

99) The elements known as the alkaline earth metals are found in Group

- (a) 1 (c) 16
(b) 2 (d) 17

100) Given the reaction:

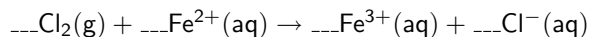

When the equation is correctly balanced using *smallest* whole numbers, the coefficient of $\text{Cl}^{-}(\text{aq})$ will be

- (a) 1 (c) 6
(b) 2 (d) 7

101) Which statement describes $\text{KCl}(\text{aq})$?

- (a) KCl is the solute in a homogeneous mixture.
(b) KCl is the solute in a heterogeneous mixture.
(c) KCl is the solvent in a homogeneous mixture.
(d) KCl is the solvent in a heterogeneous mixture.

102) Given the closed system at equilibrium:

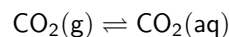

As the pressure on the system increases, the solubility of the $\text{CO}_2(\text{g})$

- (a) decreases (c) remains the same
(b) increases

103) What is the molarity of a solution that contains 40. grams of NaOH in 0.50 liter of solution?

- (a) 1.0 M (c) 0.50 M
(b) 2.0 M (d) 0.25 M

104) What is the concentration of a solution of 10. moles of copper (II) nitrate in 5.0 liters of solution?

- (a) 0.50 M (c) 5.0M
(b) 2.0 M (d) 10. M

105) What is the total number of grams of HI in 0.500 liter of 1.00 M HI?

- (a) 1.00 g (c) 64.0 g
(b) 0.500 g (d) 128 g

106) If 50 milliliters of a 1.0 M NaOH solution is needed to exactly neutralize 10 milliliters of an HCl solution, the molarity of the HCl solution is

- (a) 1.0 M (c) 5.0 M
(b) 0.20 M (d) 10. M

- 107)** As the temperature of a sample of $\text{H}_2\text{O}(\ell)$ decreases, the average kinetic energy of its molecules will
- (a) decrease (c) remain the same
(b) increase

108) A potential energy diagram of a chemical reaction is shown below.

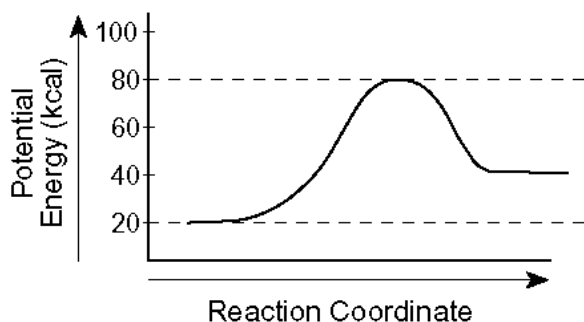

What is the difference between the potential energy of the reactants and the potential energy of the products?

- (a) 20 kcal (c) 60 kcal
(b) 40 kcal (d) 80 kcal

109) Given the reaction:

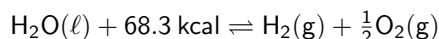

Which statement describes the reverse reaction?

- (a) It is endothermic and releases 68.3 kilocalories.
(b) It is endothermic and absorbs 68.3 kilocalories.
(c) It is exothermic and releases 68.3 kilocalories.
(d) It is exothermic and absorbs 68.3 kilocalories.

110) Which statement best describes a chemical reaction in which energy is released?

- (a) It is exothermic and has a negative ΔH .
(b) It is exothermic and has a positive ΔH .
(c) It is endothermic and has a negative ΔH .
(d) It is endothermic and has a positive ΔH .

111) The heat absorbed when ice melts can be measured in a unit called a

- (a) torr (c) mole
(b) degree (d) calorie

112) Which phase change is exothermic?

- (a) solid to liquid (c) liquid to solid
(b) solid to gas (d) liquid to gas

113) The average kinetic energy of water molecules increases when

- (a) $\text{H}_2\text{O}(\text{s})$ changes to $\text{H}_2\text{O}(\ell)$ at 0°C
(b) $\text{H}_2\text{O}(\ell)$ changes to $\text{H}_2\text{O}(\text{s})$ at 0°C
(c) $\text{H}_2\text{O}(\ell)$ at 10°C changes to $\text{H}_2\text{O}(\ell)$ at 20°C
(d) $\text{H}_2\text{O}(\ell)$ at 20°C changes to $\text{H}_2\text{O}(\ell)$ at 10°C

114) As a solid substance absorbs heat at its melting point, the melting point will

- (a) decrease (c) remain the same
(b) increase

115) The graph below represents the uniform cooling of a substance, starting with the substance as a gas above its boiling point.

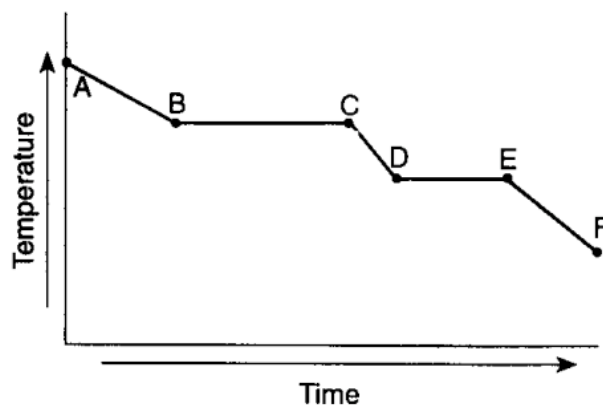

During which interval is the substance completely in the liquid phase?

- (a) AB (c) CD
(b) BC (d) DE

116) A student observed that when sodium hydroxide was dissolved in water, the temperature of the water increased. The student should conclude that the dissolving of sodium hydroxide

- (a) is endothermic
(b) is exothermic
(c) produces an acid solution
(d) produces a salt solution

For question 117

The graph below shows heat being added at a constant rate to substance A and to substance B, which begin as solids below their melting point temperatures.

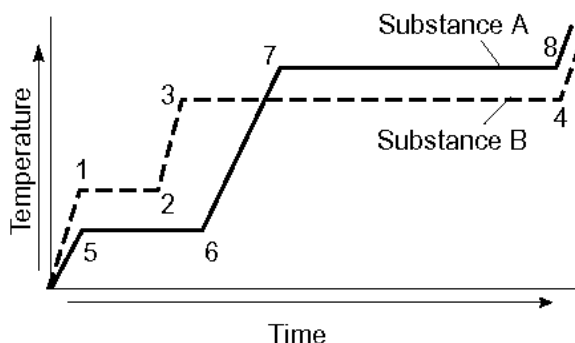

117) Compared to substance B, substance A has a

- (a) lower melting point and a lower boiling point
- (b) lower melting point and a higher boiling point
- (c) higher melting point and a lower boiling point
- (d) higher melting point and a higher boiling point

118) Given the reaction:

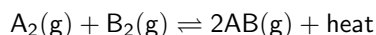

An increase in the concentration of $A_2(g)$ will

- (a) decrease the production of $AB(g)$
- (b) decrease the frequency of collisions between $A_2(g)$ and $B_2(g)$
- (c) increase the production of $B_2(g)$
- (d) increase the frequency of collisions between $A_2(g)$ and $B_2(g)$

119) A 1.0-gram sample of powdered Zn reacts faster with HCl than a single 1.0-gram piece of Zn because the surface atoms in powdered Zn have

- (a) higher average kinetic energy
- (b) lower average kinetic energy
- (c) more contact with the H^+ ions in the acid
- (d) less contact with the H^+ ions in the acid

120) Given the reaction at equilibrium:

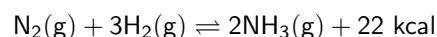

Which stress would cause the equilibrium to shift to the left?

- (a) increasing the temperature
- (b) increasing the pressure
- (c) adding $N_2(g)$ to the system
- (d) adding $H_2(g)$ to the system

121) Given the reaction:

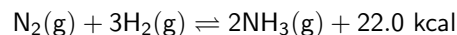

When equilibrium is reached in this system, the rate of the forward reaction is

- (a) less than the rate of the reverse reaction
- (b) greater than the rate of the reverse reaction
- (c) equal to the rate of the reverse reaction
- (d) unrelated to the rate of the reverse reaction

122) The symmetrical structure of the CH_4 molecule is due to the fact that the four single bonds between carbon and hydrogen atoms are directed toward the corners of a

- (a) triangle
- (b) tetrahedron
- (c) square
- (d) rectangle

123) Which element is present in all organic compounds?

- (a) hydrogen
- (b) nitrogen
- (c) oxygen
- (d) carbon

124) Which list of substances is in order of increasing intermolecular forces?

- (a) Ice, soda, honey, helium
- (b) Soda, ice, honey, helium
- (c) Helium, soda, honey, ice
- (d) Helium, soda, ice, honey

125) When a redox reaction occurs, there must be a transfer of

- (a) electrons
- (b) neutrons
- (c) protons
- (d) ions

126) What is the oxidation number of carbon in NaHCO_3 ?

- (a) -2
- (b) +2
- (c) -4
- (d) +4

127) Given the electrochemical cell reaction:

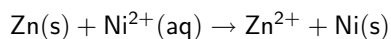

Which species is the reducing agent?

- (a) Zn
- (b) Ni^{2+}
- (c) Zn^{2+}
- (d) Ni

128) Given the reaction:

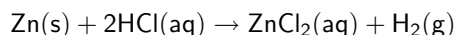

Which equation represents the correct oxidation half-reaction?

- (a) $\text{Zn(s)} \rightarrow \text{Zn}^{2+} + 2\text{e}^-$
- (b) $2\text{H}^+ + 2\text{e}^- \rightarrow \text{H}_2(\text{g})$
- (c) $\text{Zn}^{2+} + 2\text{e}^- \rightarrow \text{Zn(s)}$
- (d) $2\text{Cl}^- \rightarrow \text{Cl}_2(\text{g}) + 2\text{e}^-$

129) Which of these is the best conductor of electricity?

- (a) Distilled water
- (b) Salt water
- (c) Carbonated water
- (d) Sugar water

130) Which property do most acids share?

- (a) Bitter taste
- (b) Sour taste
- (c) Slippery feel
- (d) Faint color

131) If equal volumes of 0.1 M NaOH and 0.1 M HCl are mixed, the resulting solution will contain a salt and

- (a) HCl
- (b) NaOH
- (c) H_2O
- (d) NaCl

132) How many milliliters of 0.20 M HCl are needed to exactly neutralize 40. milliliters of 0.40 M KOH?

- (a) 20. mL
- (b) 40. mL
- (c) 80. mL
- (d) 160 mL

133) Given the equation:

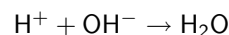

Which type of reaction does the equation represent?

- (a) esterification
- (b) decomposition
- (c) hydrolysis
- (d) neutralization

134) The following data were collected by a student performing an acid-base titration:

Volume of the acid, HCl = 20.0 mL
Molarity of the acid = 0.50 M
Volume of the base, NaOH = 40.0 mL

From the collected data, the concentration of the base should be calculated as

- (a) 1.0 M
- (b) 2.0 M
- (c) 0.25 M
- (d) 0.50 M

135) What is the pH of a solution that results from the complete neutralization of an HCl solution with a KOH solution?

- (a) 1
- (b) 7
- (c) 10
- (d) 4

136) In the reaction $\text{NH}_3 + \text{H}_2\text{O} \rightleftharpoons \text{NH}_4^+ + \text{OH}^-$, a conjugate acid-base pair is

- (a) NH_3 and H_2O
- (b) NH_3 and OH^-
- (c) H_2O and NH_4^+
- (d) H_2O and OH^-

137) At 1 atm and 298 K, which of the K_a values listed below represents the strongest acid?

- (a) 1.1×10^{-7} (c) 5.6×10^{-11}
(b) 1.8×10^{-5} (d) 4.6×10^{-4}

139) Which of the following 0.1 M solutions has the lowest pH?

- (a) 0.1 M NaOH (c) 0.1 M NaCl
(b) 0.1 M CH_3OH (d) 0.1 M HCl

138) When an acid is dissolved in water, it will-

- (a) release H^+ ions into the water.
(b) release H^- ions into the water.
(c) release OH^- ions into the water.
(d) not release ions into the water.

For question 140

pH Levels

$[\text{H}_3\text{O}^+]$	pH	Example
1×10^0	0	HCl (4%)
1×10^{-1}	1	Stomach acid
1×10^{-2}	2	Lemon juice
1×10^{-3}	3	Vinegar
1×10^{-4}	4	Soda
1×10^{-5}	5	Rainwater
1×10^{-6}	6	Milk
1×10^{-7}	7	Pure water
1×10^{-8}	8	Egg whites
1×10^{-9}	9	Baking soda
1×10^{-10}	10	Ammonia
1×10^{-11}	11	
1×10^{-12}	12	Drain cleaner
1×10^{-13}	13	NaOH (4%)
1×10^{-14}	14	

140) Which substance is the most basic?

- (a) Egg whites
(b) Water
(c) Lemon juice
(d) Vinegar

For question 141

The potential energy diagram below represents the reaction $A + B \rightarrow C + \text{energy}$.

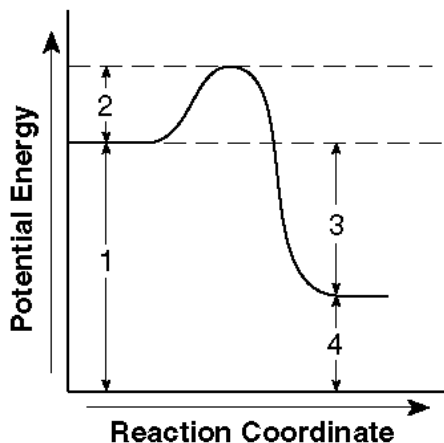

141) Which numbered interval will change with the addition of a catalyst to the system?

- (a) 1
- (b) 2
- (c) 3
- (d) 4

142) Given the reaction at equilibrium:

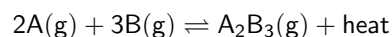

Which change will *not* affect the equilibrium concentrations of $A(g)$, $B(g)$, and $A_2B_3(g)$?

- (a) adding more $A(g)$
- (b) adding a catalyst
- (c) increasing the temperature
- (d) increasing the pressure

Section 2 - Gases and Nuclear Chemistry

143) A perfume bottle is opened at one end of the room, and after a few minutes the smell of the perfume can be detected at the other end of the room. Which statement correctly explains how the smell traveled across the room?

- (a) The perfume molecules diffused throughout the room.
- (b) The perfume molecules combined with the air molecules in the room.
- (c) The perfume molecules collided with the walls of the room.
- (d) The perfume molecules reacted with other smells in the room.

144) A gas sample has a volume of 25.0 milliliters at a pressure of 1.00 atmosphere. If the volume increases to 50.0 milliliters and the temperature remains constant, the new pressure will be

- (a) 1.00 atm
- (b) 2.00 atm
- (c) 0.250 atm
- (d) 0.500 atm

145) The graph below represents the relationship between pressure and volume of a given mass of a gas at constant temperature.

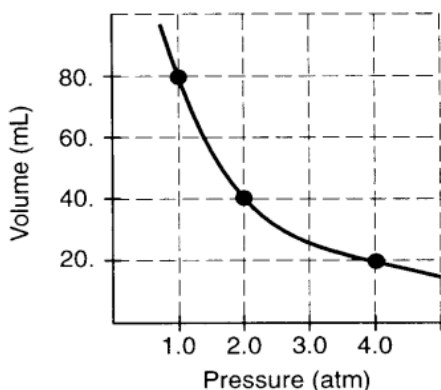

The product of pressure and volume is constant. According to the graph, what is the product in atm?

- (a) 20.
- (b) 40.
- (c) 60.
- (d) 80.

146) Which of these is the correct standard temperature and pressure?

- (a) 100°C and 1 atm
- (b) 100°C and 2 atm
- (c) 0°C and 1 atm
- (d) 0°C and 2 atm

147) What is 10°C in Kelvin?

- (a) 73K
- (b) 273K
- (c) 283K
- (d) 383K

148) What is 373K in Celsius?

- (a) 0°C
- (b) 100°C
- (c) 200°C
- (d) 300°C

149) What happens to molecules at 0K?

- (a) They move rapidly and collide often.
- (b) They move rapidly but rarely collide.
- (c) They move slowly and rarely collide.
- (d) They stop moving.

150) Which of these has base units made up of amino acids?

- (a) Protein
- (b) Phospholipids
- (c) Sucrose
- (d) DNA

151) Which statement explains why fusion reactions are difficult to initiate?

- (a) Positive nuclei attract each other.
- (b) Positive nuclei repel each other.
- (c) Neutrons prevent nuclei from getting close enough to fuse.
- (d) Electrons prevent nuclei from getting close enough to fuse.

152) In a fusion reaction, reacting nuclei must collide. Collisions between two nuclei are difficult to achieve because the nuclei are

- (a) both negatively charged and repel each other
- (b) both positively charged and repel each other
- (c) oppositely charged and attract each other
- (d) oppositely charged and repel each other

153) How are protons held together in the nucleus of an atom?

- (a) Nuclear forces
- (b) Electromagnetic attraction
- (c) Electromagnetic repulsion
- (d) Rotational inertia

154) The diagram below represents a nuclear reaction in which a neutron bombards a heavy nucleus.

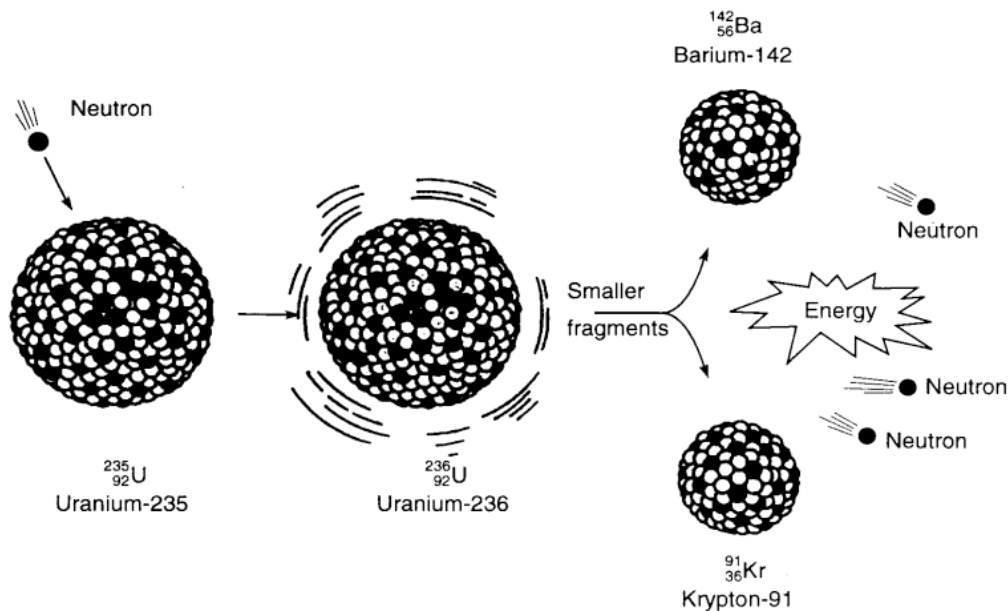

Which type of reaction does the diagram illustrate?

- (a) fission
- (b) fusion
- (c) alpha decay
- (d) beta decay

155) Given the reaction:

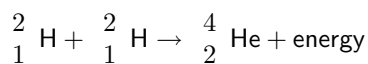

The process represented by the reaction is called

- (a) fission
- (b) fusion
- (c) artificial transmutation
- (d) alpha decay

157) Which nuclear equation represents beta decay?

- (a) ${}^{27}_{13}\text{Al} + {}^4_2\text{He} \rightarrow {}^{30}_{15}\text{P} + {}^1_0\text{n}$
- (b) ${}^{238}_{92}\text{U} \rightarrow {}^{234}_{90}\text{Th} + {}^4_2\text{He}$
- (c) ${}^{14}_6\text{C} \rightarrow {}^{14}_7\text{N} + {}^0_{-1}\text{e}$
- (d) ${}^{37}_{18}\text{Ar} + {}^0_{-1}\text{e} \rightarrow {}^{37}_{17}\text{Cl}$

156) Which type of radiation has zero mass and zero charge?

- (a) alpha
- (b) beta
- (c) neutron
- (d) gamma

158) When an alpha particle is emitted by an atom, the atomic number of the atom will

- (a) decrease by 2
- (b) increase by 2
- (c) decrease by 4
- (d) increase by 4

159) The diagram below represents radiation passing through an electric field.

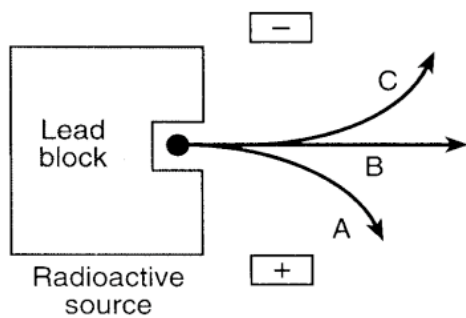

The arrow labeled *A* most likely represents

- (a) a positron
- (b) an electron
- (c) alpha radiation
- (d) gamma radiation

160) Which list is in order of increasing penetrating strength?

- (a) Alpha, gamma, beta
- (b) Alpha, beta, gamma
- (c) Gamma, alpha, beta
- (d) Gamma, beta, alpha